

# CIRCULAR STAPLER

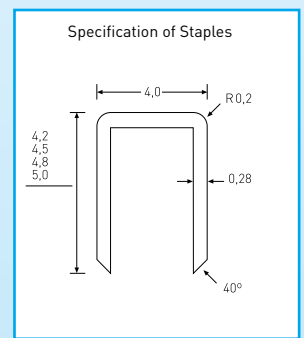
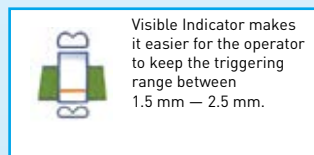
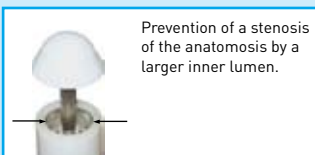
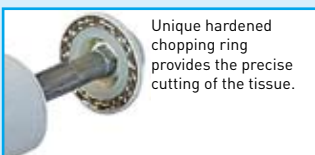
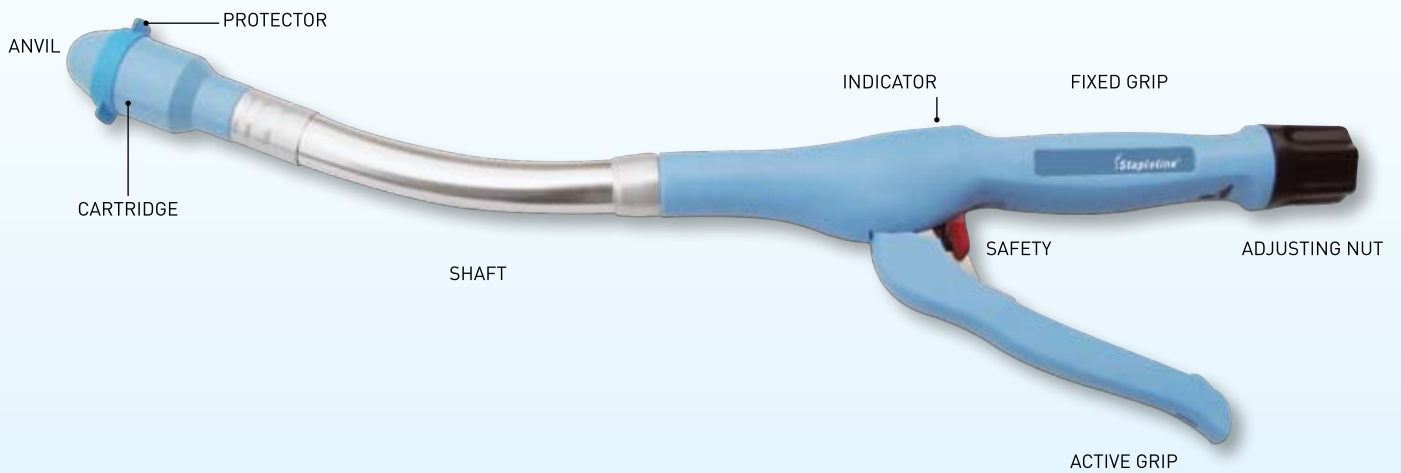

Article	Reference Code	Colour of Protector	Number of Staples	Outer Diameter*	Inner Diameter*	Leg Height*
CCA WH-Y-21	WH-Y-21	black	16	21	15,4	4.2
CCA WH-Y-24	WH-Y-24	grey	18	24	17,1	4.5
CCA WH-Y-26	WH-Y-26	red	20	26	18,8	4.5
CCA WH-Y-29	WH-Y-29	blue	24	29	21,7	4.8
CCA WH-Y-32	WH-Y-32	green	26	32	26,2	5.0
CCA WH-Y-34	WH-Y-34	brown	28	34	28,2	5.0

Circular Stapler: CCA (Curved Circular Anastomosis)

\*mm



# ZIRKULÄRER STAPLER

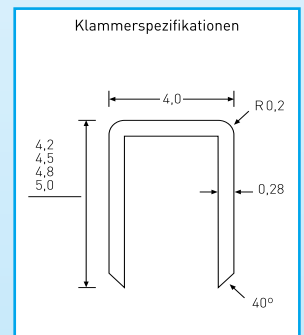
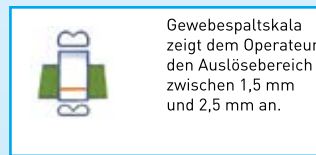
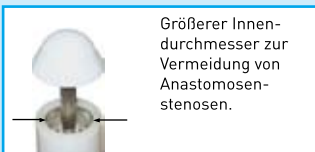
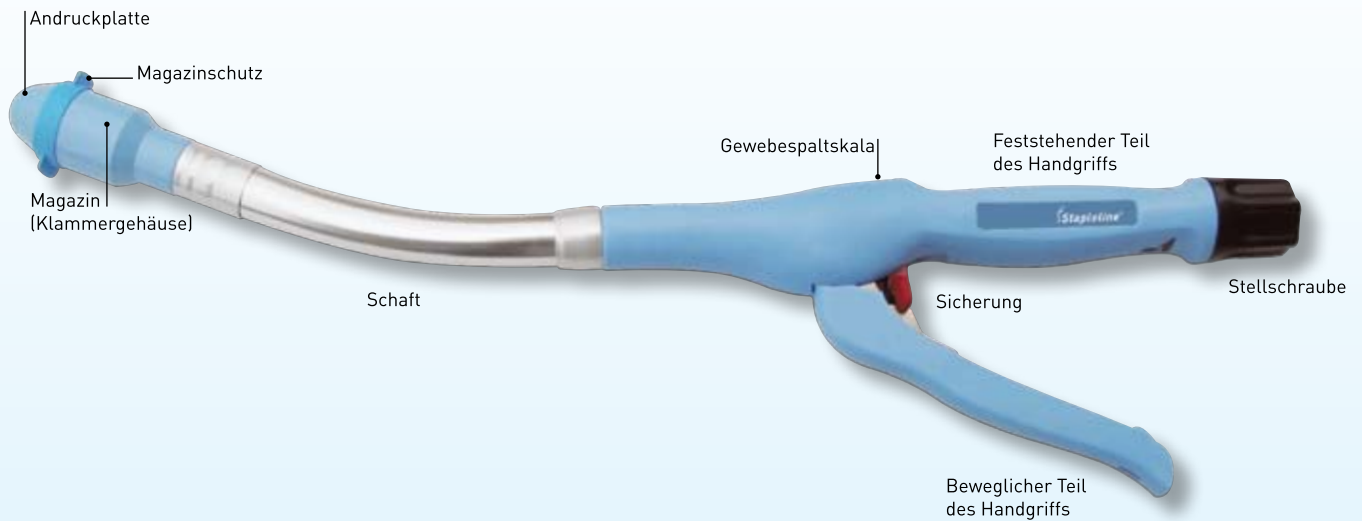

Artikel	Referenz Code	Farbe Magazinschutz	Anzahl der Klammern	Äußerer Durchmesser*	Innerer Durchmesser*	Schenkellänge*
CCA WH-Y-21	WH-Y-21	black	16	21	15,4	4,2
CCA WH-Y-24	WH-Y-24	grey	18	24	17,1	4,5
CCA WH-Y-26	WH-Y-26	red	20	26	18,8	4,5
CCA WH-Y-29	WH-Y-29	blue	24	29	21,7	4,8
CCA WH-Y-32	WH-Y-32	green	26	32	26,2	5,0
CCA WH-Y-34	WH-Y-34	brown	28	34	28,2	5,0

Circular Stapler: CCA (Curved Circular Anastomosis)

\*mm

